

SONOSAX SX-V

SWISS MADE

- High quality compact sound mixer, max. 10 channels, 19"
- Ideal for digital recording and video applications
- External level control for video editor or automation
- DC and/or AC powered with instantaneous switching system



GENERAL DESCRIPTION

The enormous interest shown in the SONOSAX SX-S for Television and Video applications has urged us to develop a new mixer to meet this demand.

The SONOSAX SX-V is made with the same technology as the SONOSAX SX-S, thereby maintaining the compact and self-contained features, designed for professional mobile and studio applications.

Built in a unique rugged, anodized aluminium chassis which can accommodate up to 10 inputs, powered solely on 100-260VAC and/or 12 to 15VDC, with an automatic and instantaneous power switching system, it provides the best solution whenever top performance, versatility and small size are important.

As an option, it may be equipped with VCA's allowing automation with a good number of video editors.

The SONOSAX SX-V is manufactured with no compromise on quality:

- Penny & Giles linear faders (83 mm travel)
- Gold plated connectors and switches
- Sealed conductive plastic rotary potentiometers

This added to a modular construction, ensures both high reliability and easy maintenance.

SUMMARY OF CHARACTERISTICS

Frequency resp: mic/line input: $\pm 0,5$ dB, 30 Hz-20 kHz

Gain range: 85 dB to 24 dB, 55 dB to -6 dB with 30 dB PAD ($\pm 0,5$ dB)

0 dBu $\cong 0,775$ V

LIN = 20 Hz-20 kHz

Gain	85 dB Fader at +10 dB	60 dB Fader at 0 dB	40 dB Fader at 0 dB
Specs.			
nom. input level	87 μ V	1,55 mV	15,5 mV
max. input level*	2,95 mV	4,15 mV	41,5 mV
tot. harm. dist.**	0,01%	0,01%	0,01%
CMRR at 1 kHz	-110 dB	-110 dB	-110 dB
CMRR**	-85 dB	-85 dB	-85 dB
Noise LIN***	-129,2 dB	-128,8 dB	-119,5 dB
Noise ASA A***	-131,5 dB	-131 dB	-121 dB

* Provision of 8 dB before clip if limiter on ∞

** 20 Hz to 20 kHz, at max. input level (with VCA, THD = 0,04%)

*** Equivalent input noise from 150 Ω source

REAR PANEL

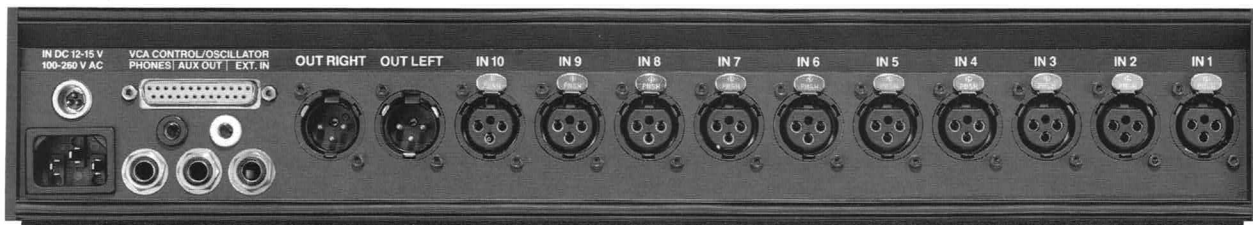

SPECIFICATIONS

MIC/LINE INPUT MODULE

Mic/Line Input:	balanced transformerless Impedance: nominal 5 k Ω or 10 k Ω with 30 dB PAD
R.F. Filter	on option
Low Frequency Filter:	12 dB/oct, 20 Hz to 500 Hz
Low Frequency Equalizer:	4 dB/oct, ± 12 dB at 80 Hz, ± 15 dB at 40 Hz
High Frequency Equalizer:	4 dB/oct, ± 12 dB at 8 kHz, ± 15 dB at 16 kHz
Mid Sweep Equalizer:	6 dB/oct, ± 11 dB, 200 Hz to 8 kHz
Limiter:	Threshold: -5 dB to ∞
Overload Indicator:	4 dB before clipping level
Mic Power Supply:	Phantom +12 V and +48 V, T12 V (DIN A-B)
VCA (on option):	DC control, 1 V/-20 dB, -100 to +10 dB

OPTIONAL TRANSFORMER LINE OUTPUT

(IN PLACE OF AN INPUT MODULE)

L + R or Aux Outputs:	nominal level: +6 dBu (1,55 V) or +15 dBu (4,4 V) max: +27 dBu with 10 k Ω load +21 dBu with 200 Ω load
Output Impedance:	50 Ω (30 Hz to 15 kHz)
Limiter:	internally adjustable

MASTER MODULE AND GENERAL

L + R Outputs:	floating balanced transformerless nominal level: +6 dBu (1,55 V) max: +24 dBu with 10 k Ω load +18 dBu with 600 Ω load (to balanced input)
Aux Output:	ground compensated output nominal level: +6 dBu (1,55 V) max: +18 dBu with 10 k Ω load +15 dBu with 600 Ω load
Ext or Tape Return:	+6 dBu, impedance 5 k Ω (internally adjustable)
Oscillator Output:	1 kHz and 10 kHz, +6 dBu with 600 Ω load
Headphone Output:	max: +15 dBu with 200 Ω load
Supply Voltage:	100 to 260 V AC, 40 to 70 Hz
External DC:	12-15 V DC
Meter:	modulometer -24 dB to +12 dB
Dimensions:	16,7" x 12,1" x 2,84" (424 x 306 x 72 mm) optional rack mount kit 19"
Total weight:	14,8 lbs (6,7 kg)
Operating temperature:	14 $^{\circ}$ F to +131 $^{\circ}$ F (-10 $^{\circ}$ C to +55 $^{\circ}$ C) standard version 50 $^{\circ}$ F to +104 $^{\circ}$ F (+10 $^{\circ}$ C to +40 $^{\circ}$ C) VCA version

MIC/LINE INPUT MODULE

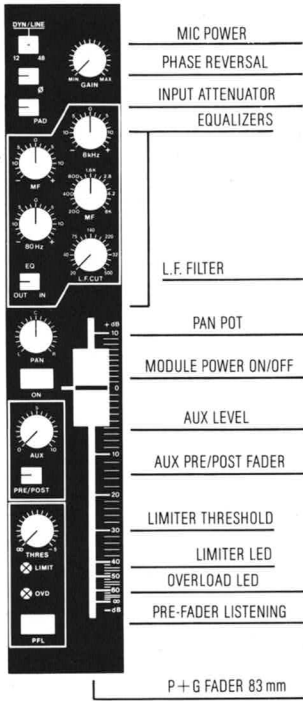

MASTER MODULE

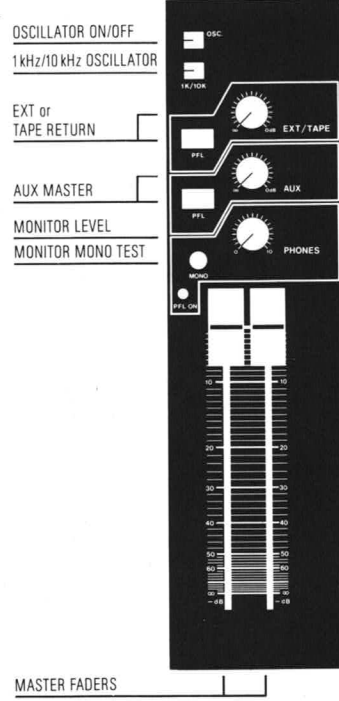

OPTIONAL TRANSFORMER LINE OUTPUT

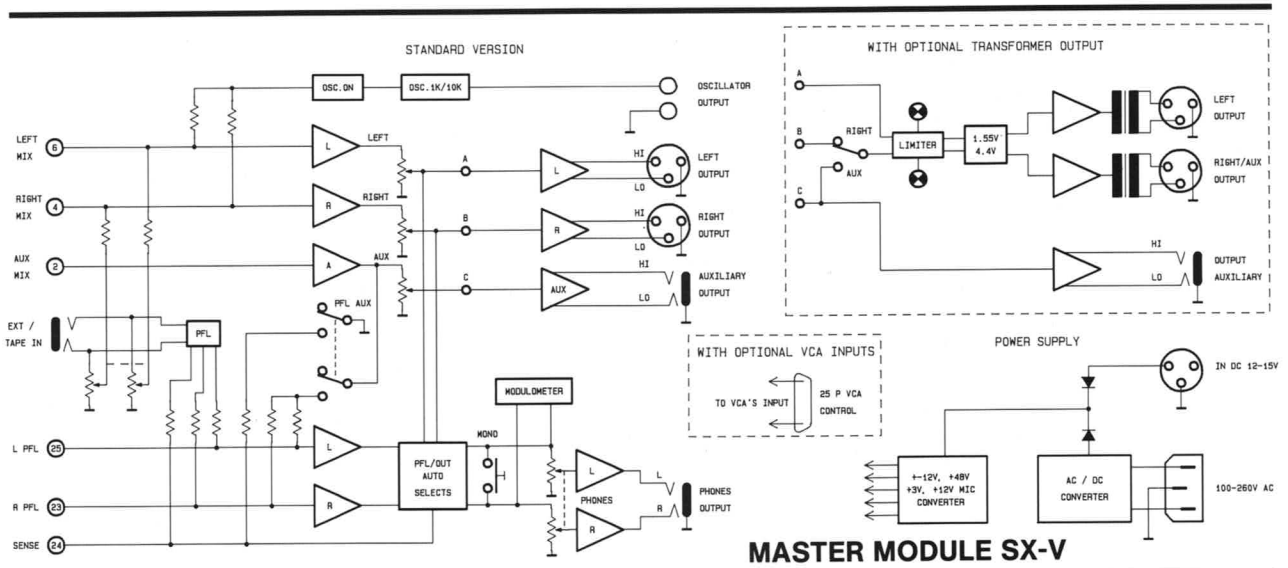
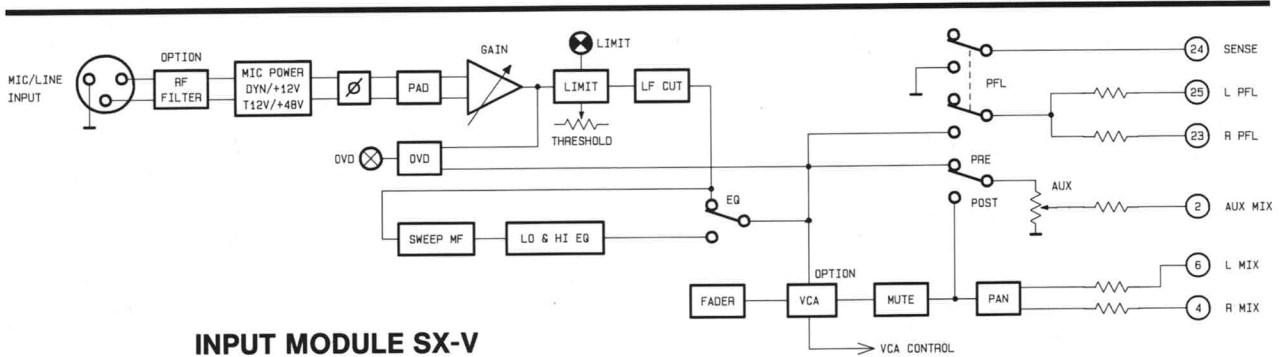

SONOSAX SX-PR SERIES

Versatile and lightweight for video, TV and digital recording, ideal for ENG/EFP applications, available in 2, 4 or 6 inputs. All set for digital recording.
SX-PR4: 1.85 kg (4.07 lbs) – only.

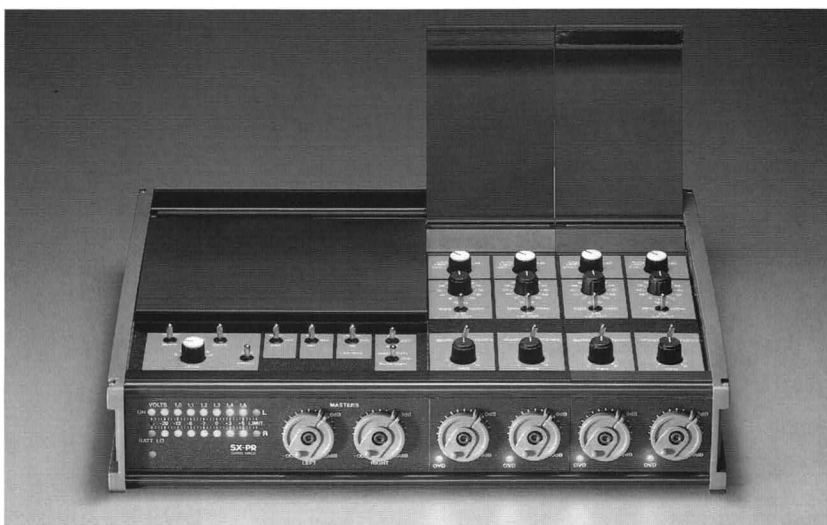

SONOSAX SX-S SERIES

The high quality modular portable mixer for professional mobile and studio application. SX-S 6 up to 6 inputs, SX-S 8 up to 8, SX-S 10 up to 10.



SONOSAX SX-T SERIES

The most compact modular system available, from 10 to 32 outputs, VCA's optional, compatible with certain video editors.

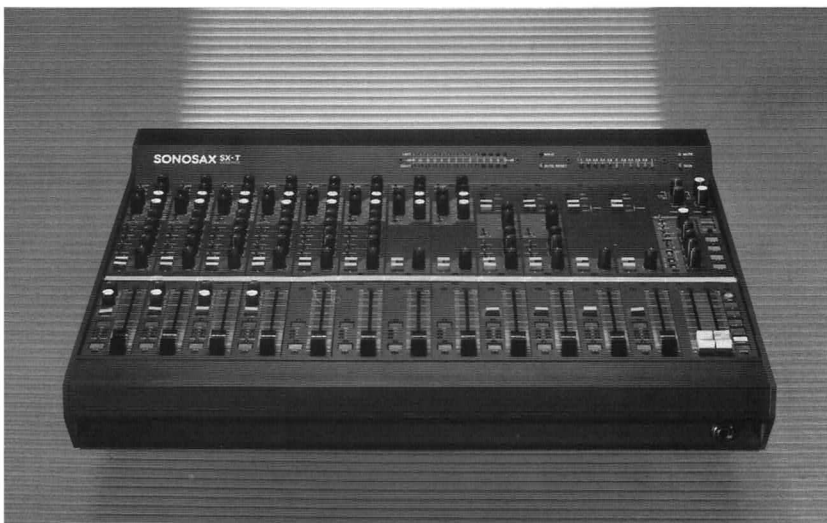

Improvements may cause change of features and specifications without notice

NEW ADDRESS FOR SONOSAX
SAS SA • Ch. de la Naz 38
CH-1052 Le Mont s/Lausanne
Tel. +4121 651 01 01
Fax +4121 651 01 09

~~000 02 02 Fax (021) 000 02 00 Telex 150 025 sx ch~~